

# LAB.GRUPPEN

***fp 6400***

**USER MANUAL**

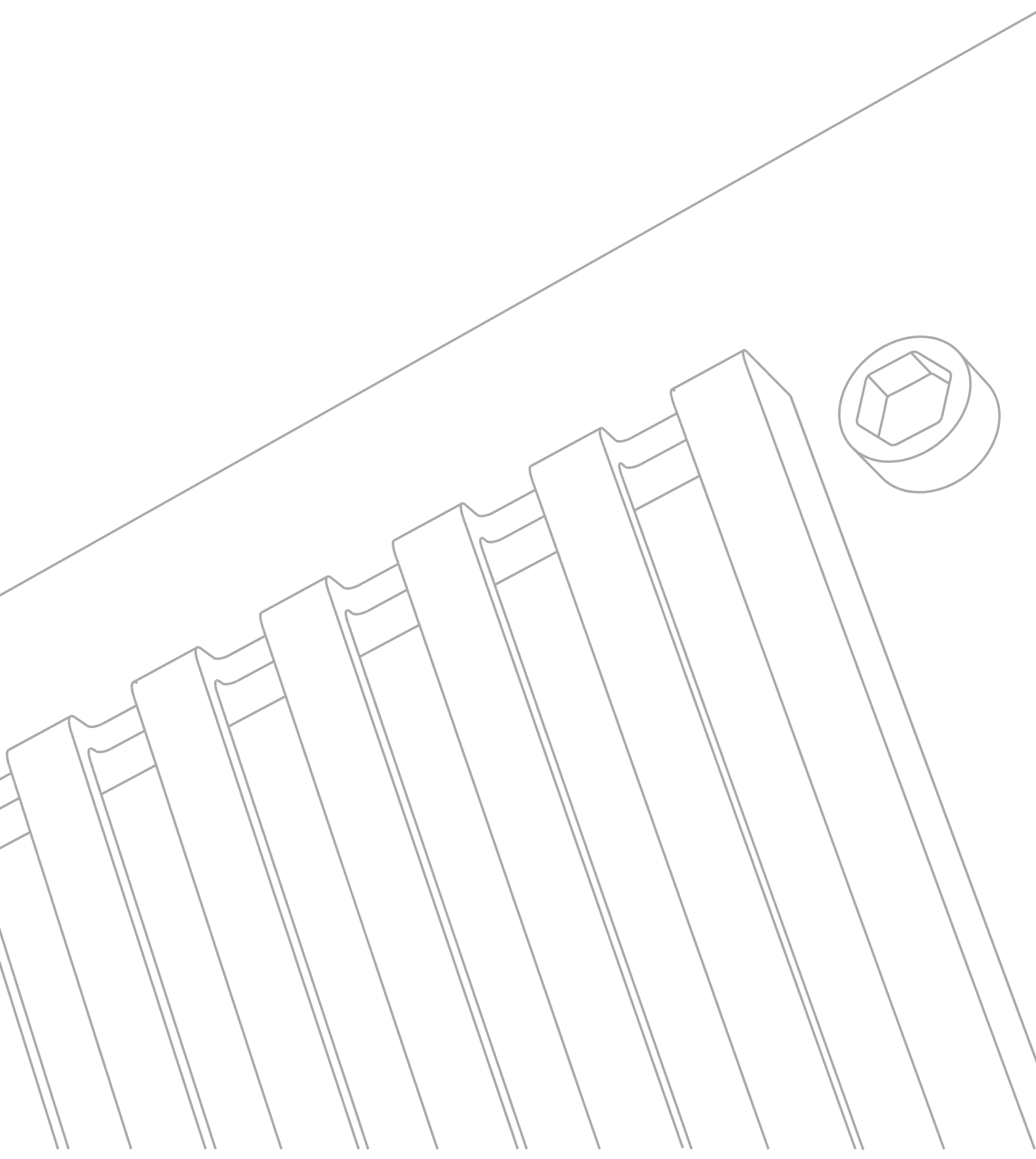

# 1 CONTENTS

1	CONTENTS .....	1
2	APPROVALS.....	2
3	WARNINGS .....	2
3.1	Explanation of graphical symbols .....	2
3.2	WARNING.....	2
3.3	CAUTION.....	2
3.4	Important Safety Instructions .....	2
3.5	User responsibility.....	3
3.5.1	Speaker damage.....	3
3.5.2	Speaker output hazard .....	3
3.5.3	Radio interference .....	3
4	INTRODUCTION.....	4
4.1	Unpacking .....	4
4.2	Front Panel .....	4
4.3	Rear Panel.....	5
5	REAR PANEL FEATURES .....	6
5.1	Gain switch.....	6
5.1.1	The DIP-switch.....	6
5.1.2	Sensitivity.....	6
5.1.3	Options .....	6
5.2	Link switch.....	7
5.3	Operation modes.....	7
5.3.1	Stereo mode.....	7
5.3.2	Note for bench test .....	7
5.3.3	Tandem mode .....	7
5.3.4	Bridge mono mode .....	7
5.3.5	Bridge mono mode features.....	8
5.4	Impedance matching (MLS switch).....	8
5.4.1	A practical way to find your MLS™ settings.....	9
5.4.2	MLS technology – the background .....	10
5.4.3	The problem .....	10
5.4.4	The solution.....	10
6	INSTALLATION.....	10
6.1	Mounting .....	10
6.2	Cooling.....	10
6.3	Operating voltage .....	11
6.4	Grounding.....	11
6.5	Power consumption .....	11
6.5.1	Calculation.....	12
7	CONNECTIONS.....	13
7.1	Input connections .....	13
7.1.1	Balanced inputs .....	13
7.1.2	Unbalanced inputs .....	13
7.2	Connecting speakers.....	14
8	OPERATION .....	14
8.1	Operation precautions.....	14
8.2	Powering up – Soft start .....	14
8.3	Input attenuators.....	15
8.4	Indicators.....	15
9	PROTECTION FEATURES.....	15
9.1.1	Clip limiter .....	15
9.1.2	Thermal protection .....	16
9.1.3	VHF protection.....	16
9.1.4	Short circuit protection.....	16
9.1.5	Automatic Fuse Saver, AFS™ limiter.....	16

9.1.6	AC mains voltage protection .....	16
9.1.7	The “AC” LED .....	17
9.1.8	DC protection .....	17
10	MAINTENANCE.....	17
10.1	Troubleshooting.....	17
11	SPECIFICATIONS .....	18
12	WARRANTY .....	19

## 2 APPROVALS



**CONFORMS TO  
ANSI/UL STD 6500  
CERTIFIED TO  
CAN/CSA-STD E60065-00**

This equipment is tested and approved according to the U.S. safety standard ANSI/ UL 6500 and Canadian safety standard CSA E60065-00. ETL made the tests and they are a Nationally Recognized Testing Laboratory (NRTL).

The ETL Listed Mark is recognized by local inspectors and Authorities Having Jurisdiction (AHJs)

throughout North America and also in some areas of South America. ITS ETL SEMKO is a NRTL recognized by OSHA (Occupational Safety and Health Administration), the ETL Listed Mark is an accepted alternative to UL and, as such, inspectors and AHJs are required by law to recognize, acknowledge, and accept the mark as proof of product compliance. See more on ETL Web:

[www.etlsemko.com/S1OurMarks/index.htm](http://www.etlsemko.com/S1OurMarks/index.htm)

## 3 WARNINGS

### 3.1 Explanation of graphical symbols



The lightning symbol within a triangle is intended to alert the user to the presence of un-insulated “dangerous voltage” within the amplifier’s enclosure that may be of sufficient magnitude to constitute a risk of electric shock to humans.



The exclamation point within a triangle is intended to alert the user to presence of important operating and service instructions in the literature accompanying the product.

### 3.2 WARNING

To reduce risk of fire or electric shock, do not expose this apparatus to rain or moisture.



### 3.3 CAUTION

To reduce the risk of fire or electric shock, do not remove screws. No user-serviceable parts inside. Refer servicing to qualified service personnel.

## 3.4 Important Safety Instructions

**Before using your amplifier, be sure to carefully read the applicable items of these operating instructions and the safety suggestions**

1. Keep this manual for future reference.
2. Heed all warnings.
3. Follow all instructions.
4. Do not use this unit near water. Do not spill water or other liquids into or on the unit. Do not operate the amplifier while wet or standing in liquid.
5. Clean only with dry cloth.
6. Do not block the air intake or exhaust ports. Install the unit in accordance with the instructions.
7. Do not operate the amplifier near heat producing devices such as radiators, heat registers, stoves or other apparatus that produce heat.



8. Always operate the unit with the chassis ground wire connected to the electrical safety earth. Do not defeat the safety purpose of a grounding-type plug. A grounding type plug has two pins and a third grounding prong. The third prong is provided for your safety. If the provided plug does not fit into your outlet, consult an electrician for replacement of the obsolete outlet.
9. Connect only to AC power outlets rated 100-120V, 50-60Hz.
10. Do not use this amplifier if the power cord is broken or frayed. Protect the power cord from being walked upon or pinched particularly at the plugs and the point where it exits from the apparatus.
11. Only use accessories specified by the manufacturer.
12. The unit is intended to use in a 19" rack. Follow the mounting instructions. When a rack on wheels is used, use caution when moving the loaded rack to avoid injury from tipping over.
13. Unplug this apparatus during lightning storms or when unused for long periods of time.
14. Do not connect an amplifier output in parallel or series with any other amplifier's output. Do not connect the amplifier output to any other voltage source, such as battery, mains source, or power supply, regardless of whether the amplifier is turned on or off.
15. Do not run the output of any amplifier back into another channel's input.
16. Refer all servicing to qualified service personnel. Servicing is required when the apparatus has been damaged in any way such as:
  - Power-supply cord or plug is damaged
  - Liquid has been spilled into the unit
  - An object has fallen into the unit
  - The unit has been exposed to rain or moisture
  - The unit does not operate normally
  - The unit was dropped or the enclosure is damaged
17. Do not remove top or bottom covers. Removal of the cover will expose hazardous voltages. There are no serviceable parts inside and removal may void the warranty.
18. An experienced user shall always supervise this professional audio equipment, especially if inexperienced adults or minors are using the equipment.



---

## 3.5 User responsibility

### 3.5.1 Speaker damage



Your amplifier is very powerful and can be potentially dangerous to both, loudspeakers and humans alike. Many loudspeakers can be easily damaged or destroyed by overpowering, especially with the high power available from a bridged amplifier. Always check the speakers' continuous and peak power capabilities. Even if the amplifier's front panel attenuators can be used to reduce the gain, it is still possible to reach full output power if the input signal level is high enough.

### 3.5.2 Speaker output hazard



Power amplifiers are capable of producing hazardous output voltages. To avoid electrical shock, do not touch any exposed speaker wiring while the amplifier is operating. See page [14](#) about outputs for proper connection of speakers.

### 3.5.3 Radio interference

This equipment has been tested and found to comply with the limits for a Class B digital device, pursuant to Part 15 of the FCC Rules. These limits are designed to provide reasonable protection against harmful interference from electrical equipment. This product uses radio frequency energy and if not used or installed in accordance with these operating instructions, may cause interference to other equipment, such as radio receivers. However, there is no guarantee that interference will not occur in a particular installation.

If this equipment does cause harmful interference to radio or television reception, which can be determined by turning the equipment on and off, the user is encouraged to try to correct the interference by one or more of the following measures:

- Reorient or relocate the antenna.
- Increase the separation between the equipment and receiver.

- Connect the equipment into an outlet on a circuit different from that to which the receiver is connected.
- Consult the dealer or an experienced radio/TV technician for help.

## 4 INTRODUCTION

Thank you for purchasing a Lab.gruppen power amplifier. This manual contains important information on operating your amplifier correctly and safely. Please take some time and read this manual to familiarize you with the advanced features of this amplifier.

### 4.1 Unpacking

Carefully open the shipping carton and check for any noticeable damage. Every Lab.gruppen amplifier is tested and inspected before leaving the factory and should arrive in perfect condition. If found to be damaged, notify the shipping company immediately. Only the consignee may institute a claim with the carrier for damage incurred during shipping. Be sure to save the carton and packing materials for the carrier's inspection.

It is also advisable to save the carton and packing material, even if the amplifier is undamaged. Should you ever need to ship the amplifier, always use the original packing.

### 4.2 Front Panel

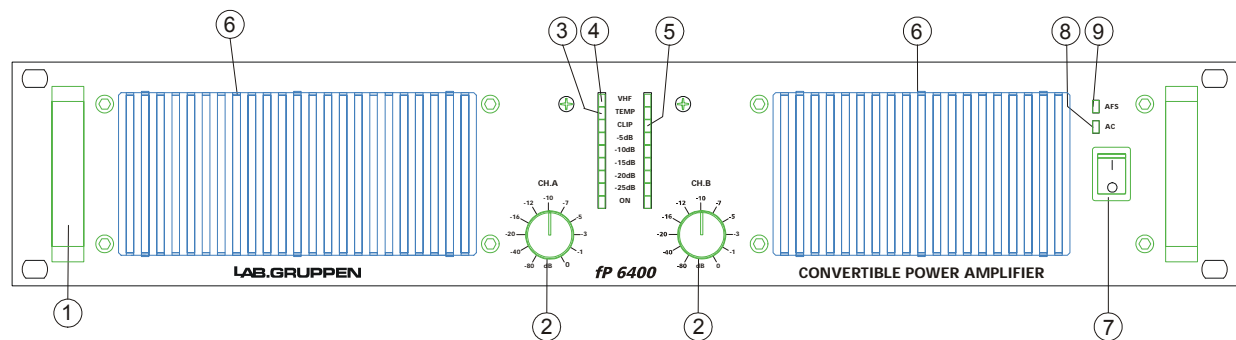

Figure 1: Front panel

#### 1. Carry/protection handle

Both handles can be used to carry the amplifier; they also act as protection for the front panel. In permanent installations, or where rack front covers are too shallow they may be removed by unscrewing the retaining bolts behind the front panel.

#### 2. Input level attenuators

These controls are used to alter the signal level entering the amplifier. They are calibrated in dB to assist the setup of active loudspeaker systems, or to cut down unwanted noise from the input signal. (See page [15](#))

#### 3. Over temperature protect indicator

This indicator illuminates if the amplifier is going to operate above its maximum operating temperature (90°C). The indicator first comes on as a warning to either turn down the input level or check the cooling arrangements. Beyond the maximum temperature the amplifier will mute the input signal. Once the cooling fans have brought the output heat sinks back to normal operating temperature the input signal is un-muted.

#### 4. VHF protect indicator

This indicator illuminates if signals above 12 kHz are continuously present at full power at the output terminals. If this occurs the input signal is muted, and the process cycles until the VHF signal is no longer present. (See page [16](#))

#### 5. Clip/limit indicator

This indicator signals if the amplifier output is clipping or limiting. It has two different indication states: If the clip limiter is engaged, it has a short time constant, and it illuminates briefly.

If the clip limiter is not engaged, it has an increased time constant, and it illuminates for a longer period. (See page [15](#))

## 6. Fan grill filters

Two grilles with foam filters are located on the front panel to prevent dust from entering the amplifier. For easy cleaning of the filters the grilles are removable by simply pulling them off. The foam filters should always be used.

## 7. Power switch

Turns mains power on or off. (See page [11](#) and [14](#))

## 8. AC indicator

Indicates if AC voltage is present. Note: Electrically this indicator is located in front of the power switch.

## 9. AFS indicator

Indicates if the AFS™ (Automatic Fuse Saver) current limiter is activated.

---

## 4.3 Rear Panel

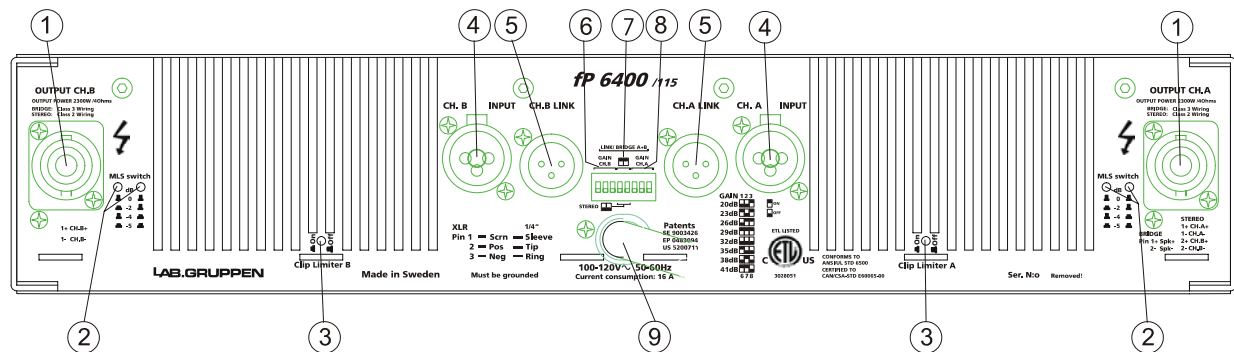

Figure 2: Rear panel

### 1. Output / Speaker connector

The Speakon connector from Neutrik® may be unfamiliar to some users. A full description can be found in the “Connections” section. (See page [14](#))

### 2. Minimum load selector (MLS™) switch

These switches are used to select the maximum output power. (See page [8](#))

### 3. Clip limiter switch

Turns the clip limiter on or off. (See page [15](#))

### 4. Input signal XLR.

Neutrik® Combojack features also ¼” TRS phone jacks. (Pin 2 is “hot”, see page [13](#))

### 5. Link output

XLR male connector connected in parallel to the female for linking the channel to another input.

### 6. Gain switch channel B

Three of the switches in the DIP switch selects the maximum gain of the channel to be either 20, 23, 26, 29, 32, 35, 38 or 41dB. (See page [6](#))

### 7. Link/Bridge switch

Two of the switches in the DIP switch are used for Link and Bridge operation. (See page [6](#))

## 8. Gain switch channel A

Three of the switches in the DIP switch selects the maximum gain of the channel to be either 20, 23, 26, 29, 32, 35, 38 or 41dB. (See page 6)

## 9. AC power cable

# 5 REAR PANEL FEATURES

Before turning the amplifier on please read the following sections to make sure that the unit is set up properly for your specific application.

## 5.1 Gain switch

The gain switch located on the rear panel (the central DIP switch) changes the input sensitivity of the amplifier. This can be handy when using low or high nominal input signals. E.g. most professional mixing consoles operate at a nominal level of +4 to +6dBu; therefore you may use the 32dB position to provide you with plenty of fader movement. On the other hand, for a disco mixer operating at a nominal level of 0dBu or less use the higher gain positions.

### 5.1.1 The DIP-switch

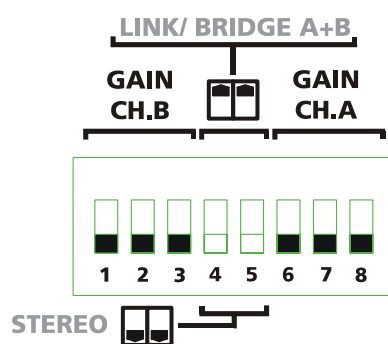

There are separate sections for the two channels, so different gain can be selected for channel A or B. The selection of maximum gain in the amplifier is always a trade between noise and headroom. A low gain amplifier amplifies less of the noise of the preceding equipment (mixer, crossover, equalizer etc.). On the other hand a higher level is needed to get full power, so the headroom will be decreased on mixer output and/or crossover units. In an actively divided system there is very often a so-called loudspeaker processor or controller involved, it being unique for the loudspeaker system. In most cases the manufacturers of these processors and/or loudspeakers recommend a specific system gain for the amplifiers.

There are eight positions with different gain, from 20dB to 41dB in 3dB steps. See the different settings for the DIP switches in the table below. The three switches to the very left are for channel B, while the three to the very right are for channel A.

### GAIN 1 2 3

20dB	
23dB	
26dB	
29dB	
32dB	
35dB	
38dB	
41dB	

6 7 8

ON  
 OFF

### 5.1.2 Sensitivity

Sensitivity is defined as how many volts (rms) or dBu (referred to 0.775Vrms) are required to get full output power. As the output power varies with the load impedance, usually 4 ohms is the reference. But in case of an MLS-switch equipped amplifier there are enough choices for full output levels into different load impedances for a sensitivity table to fill several pages. Hence we recommend calculating the sensitivity if this is necessary. Our "Audio calculator" can do this, which is an Excel file with many useful formulas. It contains help for setting up digital loudspeaker processors and can be found on our website [www.labgruppen.com](http://www.labgruppen.com): check in the "Downloads" area.

The sensitivity calculator is found in the box labeled "Amplifier gain conversions". The values to enter are in red; desired output power (see MLS table), load impedance and the selected maximum gain. The sensitivity is in the box labeled "Input level for clip" in Vrms or dBu.

### 5.1.3 Options

As the DIP switch is recessed, one may put a sticker across the bay to prevent from unauthorized changes. Another option is to completely remove the DIP switch. This should be done by authorized service personnel only! It corresponds to all switches set to "off", i.e. 32dB gain and stereo mode.

## 5.2 Link switch

The Link switch located on the rear panel (in the centre of the DIP switch) is for changing the operation mode of the amplifier (see next section 5.3).

## 5.3 Operation modes

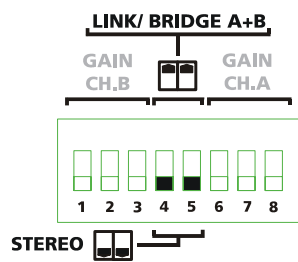

### 5.3.1 Stereo mode

In this mode both channels operate independently of each other. This is used for all 2-channel modes, such as stereo and bi-amping. Set the two centre switches to off position for the stereo mode. The level attenuators on the front panel will control the respective channels levels.

**Never connect either output terminal to ground or in parallel.** The recommended minimum nominal impedance for stereo or tandem operation is 2 ohms per channel.

### 5.3.2 Note for bench test

NOTE: Channel B is always polarity reversed on the input, but polarity compensated by feeding the minus pin on the Channel B output with the output voltage. Channel A output is connected in normal polarity mode. By having channel A and B operating in opposite polarity, the energy storage in the power supply is more efficient. This is significant for signals below 100 Hz (sub bass etc.) and improves the power bandwidth. **Be sure to use balanced inputs on all measurement equipment (also oscilloscope probes) if you are bench testing.**

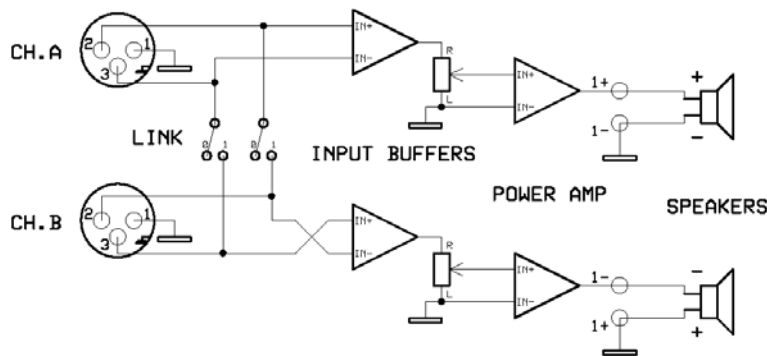

*Reverse operation of Channel B*

### 5.3.3 Tandem mode

In tandem mode both channels' inputs are linked and receive the same signal. The tandem mode is active if the Link switches are in position "On". Both level attenuators are active, allowing you to set different levels for each channel. Note that only the inputs are connected in parallel. This is NOT a parallel output mode. **Never connect either output terminal to ground or in parallel.**

You may use the remaining input connectors to carry the signal to other amps. This is called "daisy-chaining".

**NOTE: Always turn off the Link switch when using the amplifier for Bi-amping.**

### 5.3.4 Bridge mono mode

The Bridge mono mode is used to deliver both channels' power to a single load. The nominal impedance of the load must be more than 3 ohms. Set the Link switches to the "On" position and use one of the input connectors. You may use the remaining input connectors to carry the signal to other amps. Both level attenuators must be at the same position. We recommend that you set them to the 0dB (full) position. Connect the speaker as shown. Always use Channel A's output connector.

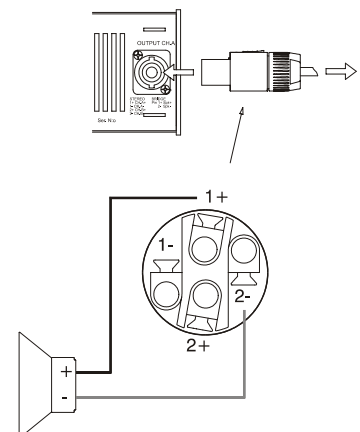

### 5.3.5 Bridge mono mode features

Bridged mono mode combines the power of both channels into one speaker. This results in twice the voltage swing, four times the peak power and just less than three times the full power of a single channel.

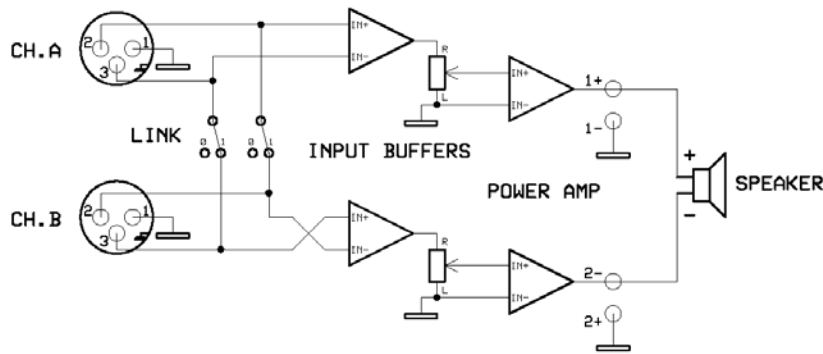

One way to understand the load and power from the amplifier's perspective in bridged mode is that it is zero voltage at the centre of the voice-coil winding. This is because the coil is driven with positive voltage at one pole and an equivalent negative voltage at the other pole. So, if an 8 ohms load is connected in bridged mode, one channel shares one 4

ohms part of the load, and the other channel shares the other 4 ohms part. The power into 4 ohms from an fP 6400 (MLS at 0dB) is 2300 watts. So, the total bridged power into an 8 ohms load will be  $2 \times 2300 = 4600$  watts.

## 5.4 Impedance matching (MLS switch)

The MLS™ switches are located on the rear panel. The MLS (Minimum Load Select) switches offer impedance matching, so you can drive the fP 6400 into 2 ohms without increased heat loss.

As stated earlier, the fP 6400 can produce 2300 watts into both, 2 and 4 ohms. Use lower MLS™ settings (e.g. -4 or -5dB) when connecting to lower impedance loads as shown in table 1. As can be seen in table 1, the fP 6400 can produce output power in excess of 2000 watts.

fP 6400		MLS SWITCH SETTING			
LOAD	CONFIGURATION	-5 dB	-4 dB	-2 dB	0 dB
16 ohms	Stereo (2 channel)	220 w	260 W	410 W	650 W
8 ohms	Stereo (2 channel)	430 W	520 W	820 W	1300 W
4 ohms	Stereo (2 channel)	830 W	1000 W	1600 W	2300 W
2 ohms	Stereo (2 channel)	1660 W	2000 W	2400 W 3050 W [2]	2900 W [1] 3200 W [2]
16 ohms	Bridged mono	860 W	1040 W	1640 W	2600 W
8 ohms	Bridged mono	1660 W	2000 W	3200 W	4600 W
4 ohms	Bridged mono	3320 W	4000 W	4800 W	5800 W [1]

[1] Depending on component tolerances.

[2] Continuous power one channel driven, or peak power both channels driven.

(Thermal protection may occur at high continuous power)

Power in watts (EIA 1 kHz, 1% THD)

Table 1

MLS™ settings can be different for each channel, and a variety of combinations can be achieved – see table 2.

Table 2 provides the simplest way to find the best MLS™ settings for your application. There is no risk to damage the amplifier since it is very well protected (even down to 0.3 ohms). The fP 6400 amplifier is a power converter, and by selecting MLS™ positions you are allocating a portion of the 6400 watts power.

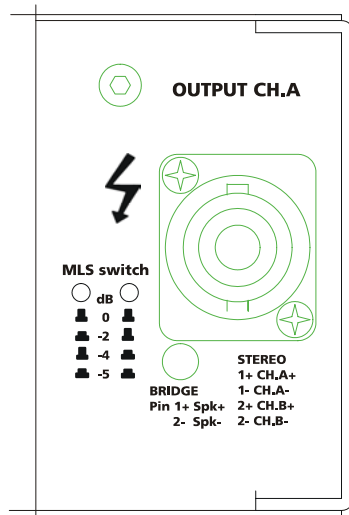

MLS switches on rear panel

### 5.4.1 A practical way to find your MLS™ settings

1. Check if the loudspeaker can take the amp's maximum output power (generally, twice the RMS power handling should be okay).
2. If the loudspeaker can handle the amp's maximum output power, leave MLS at its highest position (0dB).
3. If the loudspeaker is specified at a lower power handling, reduce the amp's output power by changing MLS to a matching lower value (-2dB, or -4dB, or -5dB).
4. Try the setup with a musical signal. If the amp runs into thermal protection, or into current limiting (audible as distortion, or as "clicks" from a cone driver/woofer), reduce the amp's output power by changing MLS to a lower value.

If you reduce the amp's output power by choosing lower MLS values, you only reduce the maximum output voltage. In fact, you will get more current headroom for low impedance loads. The amp runs at higher efficiency, and the risk for going into thermal protection is significantly lower.

Type of mode	Power/Impedance	
	Ch. A	Ch. B
Conventional mode	1300/8	1300/8
	2100/4	2100/4
	3200/2	3200/2
High voltage mode	104Vrms	104Vrms
	1300/8	1300/8
	650/16	650/16
Load matching	1300/8	1600/4
	2300/4	2400/2
	820/8	830/4
Power sharing	3200/2	1660/2
	3200/2	2300/4
	3200/2	1300/8
Limited power	1660/2	520/8
	2000/2	820/8
	1000/4	1000/4
Bi-amp mode	3200/2	2300/4
	2300/4	1300/8
	1300/8	650/16
	2300/4	830/4

Table 2

## 5.4.2 MLS technology – the background

### 5.4.3 The problem

Assume that a power amplifier can deliver 1000 watts into 8 ohms, and it should be able to run also into 2 ohms. Theoretically, and according to the physical laws, it should be able to deliver 4000 watts into 2 ohms.

Very few professional power amplifiers are able to do this, as all conventional power amplifier designs are compromises between power dissipation, cost, size etc. Most amplifiers deliver only 70% or less of their theoretical power into 2 ohms. This is due to resistive losses in the power supply and the use of current limiting to protect the output semiconductor devices from damage due to much current.

Current limiting is definitely not the best way to reduce the power at low impedances, as the limiting can produce very nasty distortion and glitches. The reason is that the impedance curve of a loudspeaker driver is not a straight line, and therefore shows a reactive load to the amplifier. This reactive load produces back energy that can trigger the current protection and may produce glitches in the signal.

### 5.4.4 The solution

The solution is to use a “Constant Power Converter”. This converter is connected in between the power supply and the linear power amplifier. The nice thing with the Constant Power Converter is that it can produce more current than it takes from the power supply, and this way overcomes the losses in the power supply when driving low impedance like 2 ohms. As power is the product of current and voltage, an increase in current requires a reduction in voltage. This reduction in voltage also causes the dissipation in the output devices to be lower. The current limit protection can be adjusted for a much higher current, so it cannot interfere with the requirements by the loudspeaker impedance curve.

## 6 INSTALLATION

### 6.1 Mounting

The amplifier is two rack units high (2U) and will fit into a standard EIA 19” rack. Amplifiers may be stacked directly on top of each other; there is no need for spacing in between units. If it is the intention to fill a rack with amplifiers, we recommend to start racking from the bottom of the rack. It is also recommended that rear supports are used for amplifiers mounted in the middle of the rack, especially if used as part of a portable system.

### 6.2 Cooling

The amplifier uses a forced air cooling system to maintain a low and even operating temperature. All fan-cooled Lab.gruppen amplifiers have front to rear airflow. There are several reasons for this, one being that there is usually cooler air outside the rack than inside, and therefore the amplifiers can run at higher continuous power levels without thermal problems. Never try to reverse the airflow, as the Intercooler® needs a pressure chamber between the fans and heat sink, and this only works in one direction of the airflow.

Should a heat sink get too hot, its sensing circuitry will mute the hot channel. If the power supply overheats, another sensing circuitry will mute all output channels, until it cools down to a safe operating temperature.

Make sure that there is an adequate air supply in front of the amplifier, and that the rear of the amplifier has sufficient space to allow the exhaust to escape. If the amplifier is rack-mounted, do not use covers or doors on the front or rear of the rack.

For installations with a central cooling system, as usually found in fixed installations with a dedicated rack room, it may be necessary to calculate the maximum heat emission. Refer to power consumption on page [11](#).

---

## 6.3 Operating voltage

### WARNING!

A label just below the mains cable on the rear of the amplifier indicates the AC mains voltage for which the amplifier is wired. Connect the power cable only to the AC source referred to on the label. The warranty will not cover damage caused by connecting to the wrong type of AC mains.

Lab.gruppen switch mode amplifiers use primary switching. The mains power is being rectified directly in front of the transformer, meaning that the power supply is insensitive to the mains frequency and will operate from DC to 400 Hz.

If the power plug is not appropriate for your country, it can be cut off and wired to a suitable connector in the following way:

<b>BLACK or BROWN</b>	<b>LIVE</b>
<b>WHITE or BLUE</b>	<b>NEUTRAL</b>
<b>GREEN or GREEN/YELLOW</b>	<b>EARTH</b>

Once the AC connector is connected to a suitable AC supply, the amplifier can be started with the power switch. When you power up the amplifier it takes a couple of seconds to check its circuits (this is known as the "soft start" or "slow start" sequence), the fans then blow at high speed before going into "idle", and the two bottom green LED's come on to show the output circuits are receiving the correct rail voltage.

---

## 6.4 Grounding

There is no ground lift switch or terminal on this amplifier. The signal ground is always floating via a resistor to chassis, and the grounding system is automatic. If a potential above 0.6V is presents in between signal ground and chassis ground, a short circuit is introduced between the two, thereby enabling electrical protection. If a unit in the system is faulty, its mains fuse will blow due to this automatic ground system. If however you wish to tie the signal ground to chassis, connect the XLR-connector's shell lug to pin 1. In the interest of safety never disconnect the earth pin on the AC power cord.

For all units that are FCC approved (radio interference), there is an AC mains filter. This filter needs the chassis ground for reference, otherwise a current loop is formed via the signal ground.

Use the balanced input to avoid hum and interference.

---

## 6.5 Power consumption

There are three ways to determine the power/current consumption of the amplifier:

**First**, the peak current draw at full output power. Under this condition the power will blow the mains breaker within 30 seconds, or the amplifier will operate for less than 2 minutes before thermally limiting. Therefore it is meaningless to state the input power at full power. The heat power at full power will anyway be limited by the protection circuits. There is no audio program material producing steadily full output power; it would be only sine wave for test purposes.

In case of the amplifier being operated at sustained full power (such as sine wave) into low impedances, the fP 6400 offers a mains current limiter called **AFS<sup>TM</sup> (Automatic Fuse Saver)**, which will limit the long-term current draw. Read more about the AFS limiter under "Protection" on page 16. There is also a Technical Note on our website [www.labgruppen.com](http://www.labgruppen.com): AFS limiting and power consumption.

It is more useful to state the **current draw** in different loads and output power levels. These figures can be found on the specification sheet. The current draw is measured in Ampere rms. This figure corresponds to the minimum value of the mains fuse needed.

We recommend you to design the power distribution at least for the current at 1/8 power, and for 1/3 power for heavy-duty demands like discotheques, etc.

**Second**, the maximum expected average current under worst case program material, which is 1/3 of full power according to the FTC standard. At this level the music will be in the state of constant clip and is therefore the highest power level one can obtain without completely obliterating the program.

**Last**, the "regular operating power" as defined by the safety standard IEC 65/ANSI/UL 6500 and used by a majority of safety agencies. The regular operating power is measured by using pink noise, and with

an average output power equal to 1/8 of full power. The one eighth of the total power is as loud as you can play music while making some attempt to avoid obvious clipping. It also corresponds to a headroom of 9dB, which is very low for regular audio program.

		MAX OUTPUT POWER		MAINS INPUT POWER			
		Power*	AFS activated	1/3 Power	1/8 Power	Idle	
		[W]	[W]	**	***		
fP 6400	8 ohms	2x	1300	1300	1230	575	105
	4 ohms	2x	2300	1450	1975	900	105
	2 ohms	2x	3200	1850	2950	1290	105

\* = Will be reduced by AFS limiter.  
 \*\* = Average power with music as program source. The amplifier driven to clip level.  
 \*\*\* = Regular music power with 9dB headroom, IEC standard power rating.

Table 3

### 6.5.1 Calculation

The **heat power** can be calculated as in the following example:

We consider a headroom of at least 5dB (1/3 of full power) and a 4 ohms load on an amplifier producing 2300 watts per channel. The 1/3 power per channel is accordingly  $2300 / 3 = 767$  watts, and total output  $2 \times 767 = 1534$  watts.

The power consumption according to the chart above is then 1975 watts. This chart shows the active power consumption of the amplifier with different loads and power levels.

The **heat power produced** is the difference between the power consumption and output power:

$1975 - 1534 = 441$  watts per amplifier.

The chart below shows the heat power produced in watts, in kcal per hour, and also in BTU per hour.

		HEAT POWER					
		1/3 Power*	1/8 Power**	1/3 Power*	1/8 Power**	1/3 Power*	1/8 Power**
		[W]	[W]	kcal / h	kcal / h	BTU / h	BTU / h
fP 6400	8 ohms	363	250	310	220	1240	850
	4 ohms	442	325	380	280	1510	1110
	2 ohms	817	490	700	420	2790	1670

\* = Average power with music as program source. The amplifier driven to clip level.  
 \*\* = Regular music power with 9dB headroom, IEC standard power rating.

The **efficiency** can also be calculated, it being the output-power divided by the input-power:

$1533 \text{ watts} / 1975 \text{ watts} = 78\%$ .

# 7 CONNECTIONS

## 7.1 Input connections

### 7.1.1 Balanced inputs

The XLR input connectors are electronically balanced, and wired according to the IEC 268 (pin 2 = “hot”), and wired in the following way:

PIN 1	GROUND/SHIELD
PIN 2	HOT (+)
PIN 3	COLD (-)

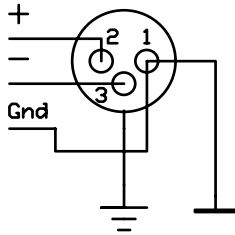

Figure 4: XLR input connector

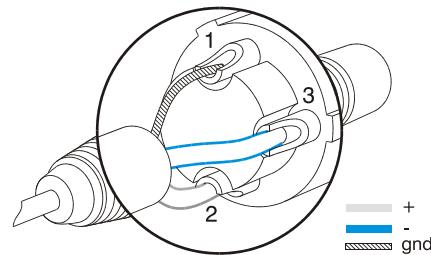

Figure 5: XLR balanced

Within the Neutrik® Combojack there is a 1/4”(6.3mm) phone jack wired in parallel with the XLR.

TIP	HOT
RING	COLD
SLEEVE	GROUND/SHIELD

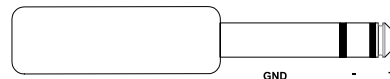
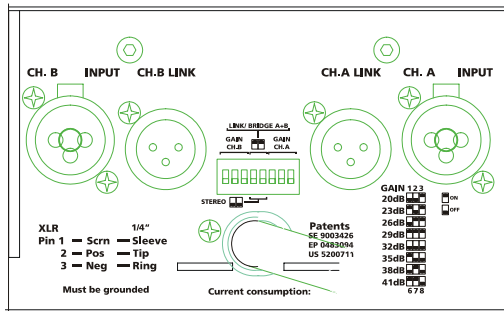

Figure 6: 1/4” TRS plug



To **daisy-chain** amplifiers, use the XLR-male connector provided on each channel, labeled “Link”. They are connected in parallel with the Neutrik® Combojack on each input.

### 7.1.2 Unbalanced inputs

To connect an unbalanced input source, connect pins 1 and 3 in the cable’s XLR plug (ring and sleeve in a TRS plug). If you leave a pin disconnected, you will lose 6dB.

A better method for using unbalanced sources is shown in figure 8. This is similar to the connection for balanced lines, but pin 3 is connected to the shield at the source end of the cable. The hum and noise rejection for the cable is equivalent to that of a balanced line. To minimize hum in the audio signal, use balanced inputs whenever possible.

Figure 7: Unbalanced line connection

Figure 8: Balanced line with unbalanced equipment

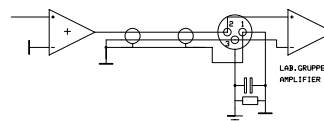
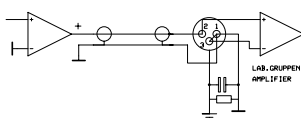

For 2-channel (stereo) operation, use both channels A and B. For tandem stereo or bridged mono operation, use only one of the inputs. See “Operation Modes” (page 7) for more details.

## 7.2 Connecting speakers

Speaker connections are made via the two **Neutrik® NL4FC Speakon** connectors. The Speakon connector is designed for high power speaker connections. It assures the correct polarity, it locks in place and prevents from shock hazard.

**They are wired in the following manner:** The right jack, Channel A, provides both channel A and B outputs, so it is useful for bridge and bi-amp operation (see bridge mono operation on page 7). The left Speakon, Channel B, carries only the channel B output.

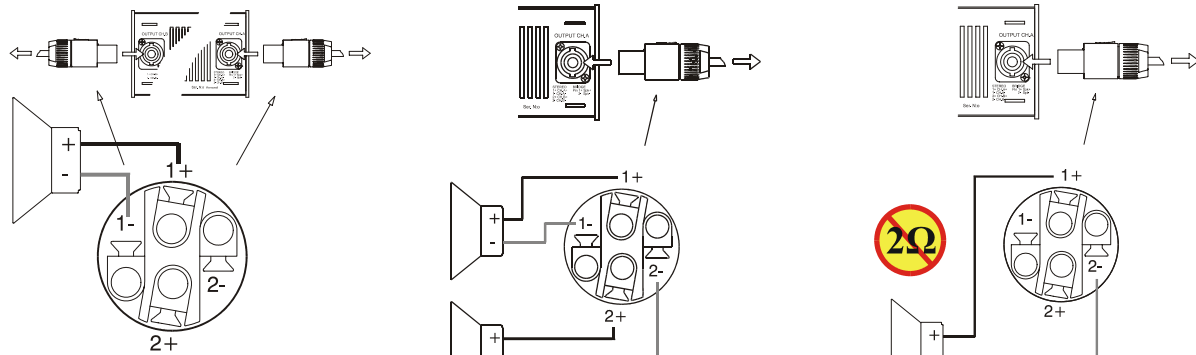

Channel A and B into two separate Speakons

Channel A and B into one Speakon (Stereo and Bi-amp)

Bridge mono

**Never connect either output terminal to ground or to some other output or input terminal.**

For regular two-channel operation connect each speaker load across the output's positive and negative terminals. **Pay attention to speaker polarity; loudspeakers connected out of polarity degrade sound quality, and may be damaged as a consequence.**

Keep the speaker cable leads as short as possible, and use a good quality stranded speaker cable. Do not use shielded leads, such as microphone or guitar cable. Remember that the speaker cable robs the power of the amplifiers in two ways: by increasing the load impedance, and by introducing resistive power losses.



**WARNING:** To prevent from electrical shock, do not operate the amplifier with any portion of the speaker wire's conductor exposed.

## 8 OPERATION

### 8.1 Operation precautions

- Make sure that the power switch is set to "off" before connecting any input or output, or operating the switches on the rear panel. See page 10 regarding installation.
- Make sure that the AC mains voltage is correct, and the same as the one printed on the rear panel of the amplifier. See page 11 regarding operating voltage and power consumption.
- Make sure that the switches on the rear panel for operation modes, gain switch, clip limiters, and the MLS switches are in the correct position. See page 7 regarding operation modes, page 15 regarding clip limiters, and page 8 regarding the MLS switches.
- It is always a good idea to turn down the gain controls during power-up to prevent from speaker damage in case of a high signal being present at the input.

### 8.2 Powering up – Soft start

When you power up the amplifier it takes a couple of seconds to check its circuits. This is known as the "soft-start" or "slow-start" sequence. The fans first blow at high speed before going into "idle", and the two bottom green LED's illuminate to show that the amplifier is operational.

## 8.3 Input attenuators

The two input level attenuators on the front panel adjust the signal level for their respective amplifier channel in all modes. They are calibrated in dB to assist the setup of active loudspeaker systems, or to cut down unwanted noise from the input signal.

In bridge mode both controls must be in the same position, so that the speaker load will be shared equally between the channels.

## 8.4 Indicators

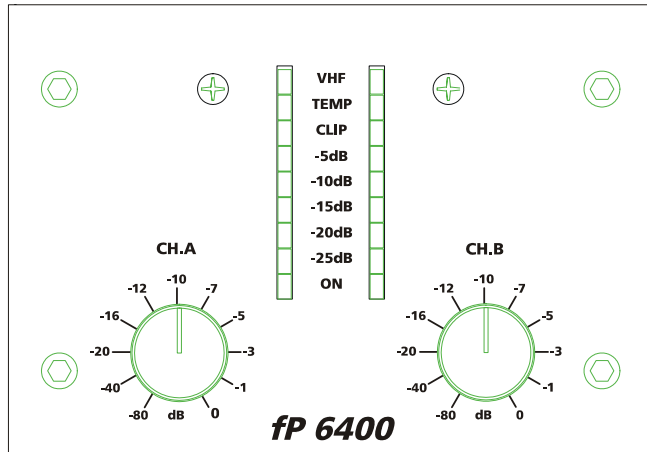

Front panel indicators

The yellow LED's indicate if any protection circuits are activated. The protections are described further below on this page ([15](#)).

The **Clip indicator** tells if the amplifier output is clipping or limiting. It has two different indication statuses:

- If the clip limiter is enabled, it has a short time constant, and it illuminates briefly.
- If the clip limiter is disabled, it has an increased time constant, and it illuminates for a longer period.

The "-25dB" LED's illuminate if the output signal is greater than -25dB (with 0dB as reference to full output power). These LED's also act as signal presence indicators.

The rest of the green LED's form a bar for output levels from -20dB to -5dB.

The green bottom "ON" LED's indicate that the output circuits are receiving the correct rail voltage.

## 9 PROTECTION FEATURES

Each Lab.gruppen amplifier has many advanced protection features. Should a fault condition arise they are protecting both, the amplifier and the speakers connected to it. Under normal use these features are inaudible. All protection circuits work independent from each other.

### 9.1.1 Clip limiter

The clip limiter is included to prevent from dangerous clipped signals reaching the speaker and damaging it. If an amplifier is severely overdriven, its output waveform is clipped (its peaks are squared off) – reducing the crest factor. In extreme cases the waveform can approach that of a square wave. An amplifier is normally capable of producing far more power under these conditions than its normal undistorted rated output power.

The limiter works by monitoring the output and comparing the distortion produced between the input and output of the amplifier. If the distortion exceeds 1% THD for any reason (voltage or current clipping), the limiter reduces the input signal proportionally. Note that, if the signal is distorted or clipped before it reaches the amplifier, the clip limiter cannot detect it, and will not be activated.

During normal operation the clip limiting is inaudible. The limiter can be turned on or off by using the relevant clip limit switch. Note that in Bridge mode the limiters of both channels should be in the same position, either on or off.

Some manufacturers of loudspeaker controllers do not recommend the use of clip limiters in amplifiers, as they tend to upset the tracking of the controller's limiters.

Apart from this single exception, Lab.gruppen recommend to leave the clip limiters switched "on" (button depressed). As a side-effect, once the amplifier comes out of a protect condition, the output level has a slow rise time – the effect is like turning up the gain slowly.

### 9.1.2 Thermal protection

If the amplifier is driven very hard into a low impedance load, the cooling fans will run at high speed. If the causing conditions continue, the "Temp" temperature indicator(s) will illuminate indicating that the amplifier is about to go into thermal shutdown.

After approximately five seconds the amplifier will go into thermal protection by muting the input signal. After another 15-20 seconds the amplifier should have cooled down enough for the amplifier to come out of shutdown and operate as normal. If the load conditions remain unchanged, the thermal protection will be reinitiated accordingly. Thermal protection starts, if the **Intercooler**<sup>®</sup> heatsink reaches a temperature above 90° C.

### 9.1.3 VHF protection

If a signal above 12kHz is detected at the amplifier outputs for more than five seconds at full output power, the VHF protection mutes the input signal. This is indicated by the LED's on the front panel labeled VHF. After five seconds the outputs will un-mute and return to normal operation, unless the output signal has remained unchanged, in which case the VHF protection will re-initiate.

### 9.1.4 Short circuit protection

All Lab.gruppen amplifiers are completely short circuit protected. The protection circuitry permits very high peak currents, but still holds the output devices within the safe operation levels. If a short circuit remains to be present, the channel effected will eventually go into thermal protect cycle until the short circuit has been removed.

### 9.1.5 Automatic Fuse Saver, AFS<sup>™</sup> limiter

The AFS<sup>™</sup> circuitry continuously monitors the mains current. If the average mains current is too high for a 16 ampere slow blow fuse, as it can be during so-called bench tests, the AFS<sup>™</sup> limiter will limit the mains current to a safe level.

If the AFS limiter is activated, this will be indicated by the AFS LED on the front panel. The AFS limiter will not be activated during normal use, even under sustained heavy clipping.

AFS<sup>™</sup> is an abbreviation for Automatic Fuse Saver. The main reason for its presence is to avoid blowing the mains breaker if a bench test is made at continuous full power.

The AFS<sup>™</sup> circuitry is a current limiter, limiting the mains power current draw to 20A (230V) or 40A (115V). The circuitry has the same characteristics as a mains breaker, so it allows for high peak currents without significantly reducing the long-term average power, but limiting the current if the amplifier draws a high continuous current. It is the continuous average current that blows the mains breaker.

The AFS LED on the front panel indicates the AFS<sup>™</sup> circuitry limiting the mains power current or the regulated power supply going out of stabilization. The power supply will go out of stabilization at low mains voltage in combination with low load impedance and during the start-up sequence. Since 1997, when this feature was introduced, not a single user has reported that the AFS<sup>™</sup> has been activated during music performance, even in high power demanding situations.

If the average current draw exceeds what the mains breaker can take (e.g. during bench test), the output power is getting reduced by 2dB. This is the same as an fP 6400 being reduced to the power of an fP 3400 (but again, not a single user has reported that the AFS has been activated). In reality this is much better than the mains breaker blowing and the amplifier being turned off. A listener can hardly hear this reduction, as only the headroom will be reduced. If the peaks are around 120 to 130dB, a 2dB reduction can hardly be noticed.

### 9.1.6 AC mains voltage protection

If the AC mains voltage is lower or higher than the allowed operational voltage (over- or under-voltage), the power supply will automatically shut down. Once the mains voltage is above the minimum start voltage and below its maximum operating voltage the amplifier will restart.

It takes a couple of seconds to self-check (this is known as the "soft start" or "slow start" sequence), the gain will slowly and gradually be increased back to the previously set level, and the fans will first blow at high speed before going into "idle". The two green "ON" LED's indicate that the power supply is operating properly.

### 9.1.7 The "AC" LED

This green LED indicates that there is proper mains power present at the incoming mains power conductors. Electrically it is located in front of the power switch and soft-start circuitry, so it lights up even if the power switch is set to off.

Instead of the power switch on the front panel switching the mains the fP 6400 has a power-relay in the soft-start circuitry. This method is more reliable and takes less space than the conventional method that requires a huge power switch. However, some governmental safety standards require that there is an indicator informing about the presence of mains power at the circuits if the power is switched by a relay.

### 9.1.8 DC protection

There are two types of DC protection:

- Fuses on the supply branches of each channel.
- A DC crowbar protection that shorts the output if more than 10 volts DC are being detected on the outputs.

Either of these protections comes into effect once DC voltage is being detected, independently for both channels.

---

## 10 MAINTENANCE

Under normal use the amplifier should provide years of trouble-free service. The only user maintenance required by the user is to vacuum the front grille periodically.

In some extreme cases it may be necessary for authorized service personnel to clean the inside of the amplifier. These conditions usually occur after prolonged use, e.g. in environments using "cracked oil" smoke machines.

If you are using your amplifier for heavy duty use, i.e. for concert touring or with "industrial" music, it is recommended to have your amplifier serviced every 3 years, purely as a preventative measure.

---

### 10.1 Troubleshooting

These are typical things to check if you think your amplifier is faulty:

**Fault: No output.**

If the output bar-graph is illuminating, there is nothing wrong with the amplifier; the likely cause is an unsecured Speakon speaker connector.

Check also if the VHF protection is activated. If it is, remove possible high frequency oscillations from the relevant input.

**Fault: The amplifier goes into thermal protection when running at low levels.**

Check that nothing causes a short circuit at the amplifier's output, e.g. any component in the loudspeaker (this can occur when the speaker coil gets hot).

**Fault: The amplifier goes into protection with the power indicators off.**

Check if the AC mains voltage is within the amplifier's operating range, 130-265V at nominal 230V (65-135V at nominal 115V). Over-/under-voltage protection may have occurred. If the amplifier was incorrectly connected to a 3-phase distribution by mistake, an internal non-resettable fuse or resistor may have blown. In this case return the amplifier to your supplier for service.

**Fault: The amplifier does not respond even after having checked the above items.**

In the unlikely event of on a non-user-rectifiable fault return the amplifier to your supplier, or an approved service centre.

**Lab.gruppen cannot be held responsible for damage or injury as a result of the top or bottom cover being removed.**

# 11 SPECIFICATIONS

## fp 6400

Max output power <sup>1)</sup>	EIA				FTC
	EIA at 1 kHz and 1% THD				20–20 kHz at 0.1% THD
MLS-switch	–5 dB	–4 dB	–2 dB	0 dB Full	0 dB Full
16 Ω per channel	220 W	260 W	410 W	650 W	640 W
8 Ω per channel	430 W	520 W	820 W	1300 W	1280 W
4 Ω per channel	830 W	1000 W	1600 W	2300 W	2200 W
2 Ω per channel	1660 W	2000 W	2400, 3050 <sup>3)</sup> W	2900 <sup>2)</sup> , 3200 <sup>3)</sup> W	2500 W
16 Ω bridged	860 W	1040 W	1640 W	2600 W	2500 W
8 Ω bridged	1660 W	2000 W	3200 W	4600 W	4400 W
4 Ω bridged	3400 W	4000 W	4800, 6100 <sup>3)</sup> W	5800 <sup>2)</sup> , 6400 <sup>3)</sup> W	5000 W

### Max output voltage

8 ohms load	62 Vrms	70 Vrms	85 Vrms	104 Vrms
Peak voltage, no load	88 V	101 V	121 V	149 V

### Distortion etc.

THD 20Hz-20kHz and 1W to full power	0.1 %
THD @ 1kHz and –1dB under dip	0.04 %
DIM 30 at –3dB under dip	0.06 %

### Hum and Noise

<–110 dB

### Channel separation @10kHz

70 dB

### Output impedance

60 mΩ

### Slew Rate

20 V/μs

### Inputs

Gain, selectable [dB]	20, 23, 26, 29, 32, 35, 38, 41
Impedance	20 kohm
Common mode rejection	50 dB

### Front Panel

Gain controls	(2) channel A, B	31 pos detent
Clip Indicator	(2) red LEDs	
Output headroom indicators	(10) green LEDs	Fast peak – slow release
Temp Indicator	(2) yellow LEDs	80°C at heatsink
VHF indicator	(2) yellow LEDs	>12 kHz at full power
On Indicator	(2) green LEDs	DC rail voltage for channel A and B
AC Indicator	(1) green LED	AC power present
AFS Indicator	(1) green LED	Fuse saver activated

### Rear Panel

Input connectors	(2) Neutrik Combo XLR type, 3 pin and 1/4" jack
Link connector	(2) XLR type, 3 pin male
Output connectors	(2) Neutrik 4-pole Speakon® connectors

### Switches:

Clip limiter A and B	On–Off (switchable)
MLS switch	0, –2, –4, –5 dB
Link-switch	Ch. A–B

### Power

	230 V version	115 V version
Operation voltage	130 V–265 V AC	65 V–135 V AC
Minimum start voltage	175 V	85 V AC
Full output power at 4ohms	180 V–265 V AC	90 V–130 V AC
Peak inrush current (Soft start limited)	5 A	5 A

### Current Draw @ 4ohms

Quiescent power (no load)	1 Arms	2 Arms
1/8 of full power (–9 dB)	6 Arms	12 Arms
1/3 of full power (–5 dB)	14 Arms	28 Arms
At full power (0 dB)	20 Arms	40 Arms
@1 kHz 1% THD	(AFS limited)	(AFS limited)

### Net Dimensions

mm	483 (19") W × 88 H × 347 D
inch	19" W × 3.5" H × 13.7" D

### Shipping Dimensions

mm	560 W × 180 H × 500 D
inch	22" W × 7.1" H × 19.7" D

### Weight

Net	10 kg (22 lbs)
Shipping	11.6 kg (25.6 lbs)

### Approvals

CE	
Emission	EN 55 103-1, E3
Immunity	EN 55 103-2, E3, with S/N below 1% at normal operation level <sup>4)</sup>
Safety	EN 60065, class I
ETL listed:	Conforms to ANSI/UL STD 6500 and Certified to CAN/CSA E60065-00
FCC:	Complies with Class B digital device, Part 15 of the FCC Rules.

### NOTES:

- 1) Specifications measured with 230 V AC
- 2) Component tolerance dependent
- 3) Continuous power, one channel driven or peak power both channels driven (Thermal protection may occur at high continuous power)
- 4) Normal operation level 1/8 of full power or –9 dB below clip level.

Lab.gruppen reserve the right to alter functions or the specification without prior notice.

## 12 WARRANTY

### General

This product is manufactured by Lab.gruppen and is warranted to be free from defects in components and factory workmanship under normal use and service for a period of three (3) years from the date of original purchase from an authorised Lab.gruppen dealer.

When failing to perform as specified during the warranty period we will undertake to repair, or at our option, replace this product at no charge to its owner, provided the unit is returned undamaged and shipping prepaid, to an authorised service facility or to the factory.

This warranty shall be null and void, if the product is subjected to: Repair work or alteration by a person other than those authorised by us; mechanical damage including shipping accidents; war, civil insurrection, misuse, abuse, operation with incorrect AC voltage, incorrect connections, wrong accessories, incorrect use of accessories, operation with faulty associated equipment, exposure to inclement weather conditions and normal wear and tear. Units, on which the serial number has been removed or defaced, will not be eligible for warranty service.

Lab.gruppen shall not be responsible for any incidental or consequential damages. Lab.gruppen's responsibility is limited to the product itself. Lab.gruppen take no responsibility for any loss due to cancellation of any events, or rent of replacement equipment or costs due to third party's or customer's loss of profit, or any other indirect cost or losses however incurred.

Lab.gruppen reserve the right to make changes or improvements in design or manufacturing without assuming any obligation to change or improve products previously manufactured.

This warranty is exclusive, and no other warranty is expressed or implied. This warranty does not affect your statutory rights.

### International

Please contact your supplier for this information, as rights and disclaimers may vary from country to country.

### Technical assistance and services

#### International

If your Lab.gruppen product needs repair, contact your Lab.gruppen dealer or distributor, or contact Lab.gruppen by fax or email to obtain the location of the nearest authorised service centre.

#### Factory services

In the event of your Lab.gruppen product needing factory service, you may contact Lab.gruppen's service department for return instructions and a Return Authorisation number.

Please note for product return

1. Use the original packing.
2. Include a copy of the sales receipt, your name, return address, phone and fax number, email address and description of the defect.
3. Mark the Return Authorisation number on the outside of the packing.
4. Ship the product prepaid to:

**Lab.gruppen AB**  
**Gullregnsvägen 16**  
**SE 434 44 Kungsbäcka**  
**SWEDEN**  
**Phone: +46 (300) 56 28 00**  
**Fax: +46 (300) 56 28 98**  
[info@labgruppen.com](mailto:info@labgruppen.com)  
[www.labgruppen.com](http://www.labgruppen.com)

**In the United States**  
**TC Electronic**  
**742-A Hampshire Road**  
**Westlake Village, CA 91361**  
**Phone: (805) 373-1828**  
**Fax: (805) 379-2648**  
[info@tcus.com](mailto:info@tcus.com)